

High Energy Physics

Lecture 5

The Passage of Particles through Matter

Introduction

- In previous lectures we have seen examples of tracks left by charged particles in passing through matter.
- Such tracks provide some of the most important information on particles
- The main mechanism by which charged particles become visible is ionization
- In this lecture we shall learn more about the passage of particles through matter
- We begin by discussing the passage of charged particles through matter

The Passage of Charged Particles through Matter

- Consider a beam of charged particles travelling along parallel paths in vacuum and entering a region of space filled with matter
- Most particles will continue travelling along roughly straight paths and lose energy through ionization of the atoms along their paths
- Some of the particles are scattered through large angles: this results in loss of beam intensity (attenuation)
- Charged particles are **either** electrons **or** heavy charged particles: the lightest particle that is heavier than the electron is the muon whose mass is about 200 times that of the electron

Artist's impression of heavy particles travelling through matter

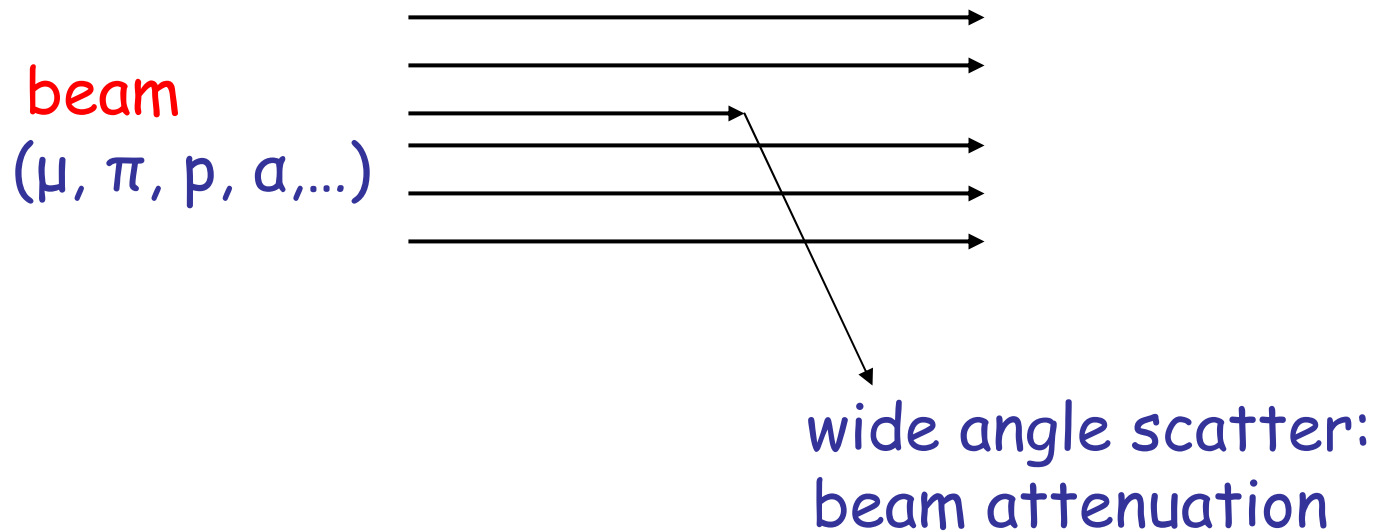

(of course if there is also a magnetic field, then the tracks are bent. But for now we work in a magnetic field free medium)

The main mechanism of energy loss is *ionization*. Ignoring the atomic Binding Energy (BE), the maximum energy loss per collision resulting in ionization is from energy and momentum conservation in nonrelativistic approximation

$$\frac{\Delta T_{\max}}{T} \simeq 4 \frac{m_e}{m} \quad \text{where } m \gg m_e$$

here T is the initial KE and ΔT_{\max} the energy imparted to an electron and hence lost by the particle

m is the particle mass and m_e is the electron mass

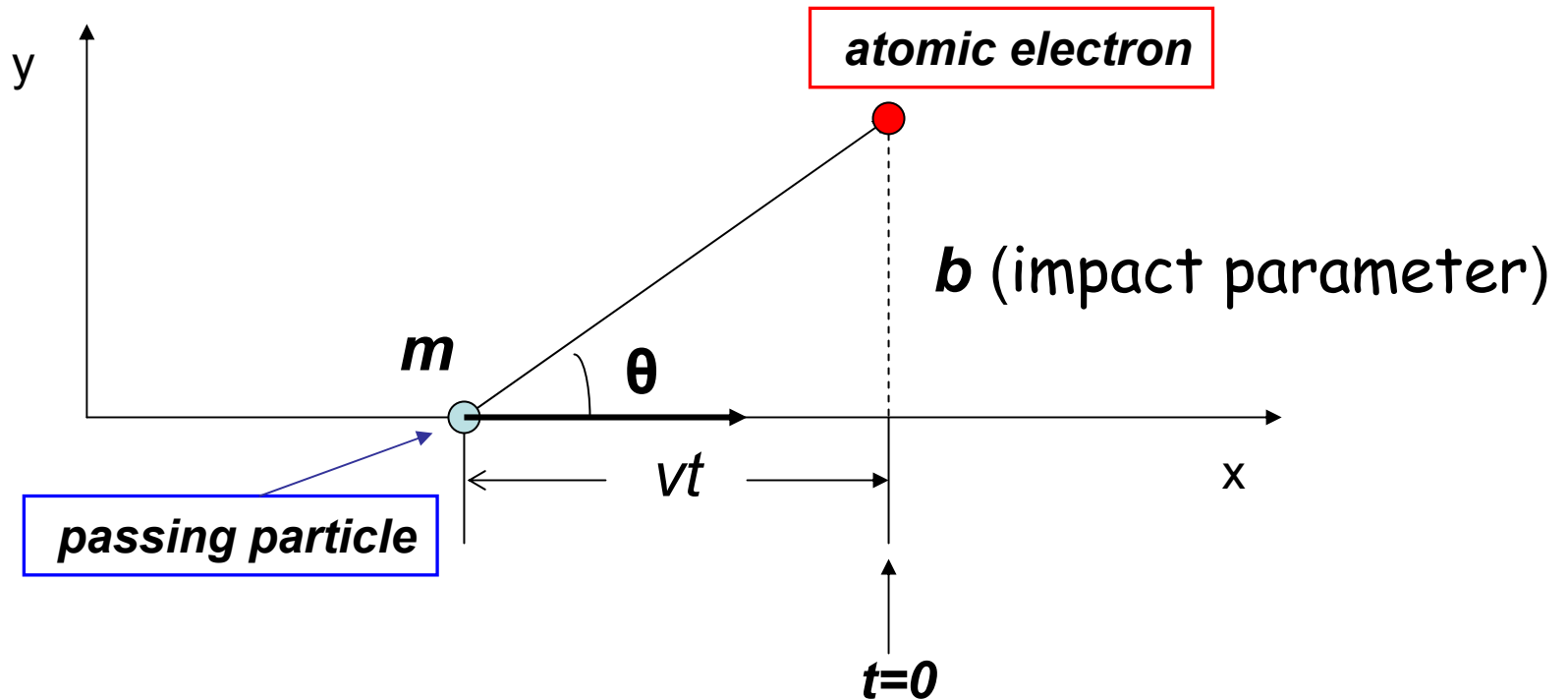

From classical mechanics: **momentum = impulse**

$$p_x = \int_{-\infty}^{\infty} F_x dt = 0$$

$$p_y = \int_{-\infty}^{\infty} F_y dt$$

The force F is the Coulomb force:

$$F_y = \frac{ze^2}{4\pi\epsilon_0 r^2} \sin \theta$$

From our figure we have:

$$vt = b \cot \theta, \quad r = b / \sin \theta$$

hence

$$dt = \frac{b}{v} d \cot \theta = \frac{b}{v} \frac{1}{\sin^2 \theta} d\theta = \frac{r^2}{vb} d\theta$$

and

$$F_y dt = \frac{ze^2}{4\pi\epsilon_0} \frac{1}{vb} \sin \theta d\theta$$

at $t = -\infty$ we have $\theta = 0$

and at $t = +\infty$ $\theta = \pi$

and hence the y component of momentum acquired by the electron is

$$p_y = \frac{ze^2}{4\pi\epsilon_0 v b} \int_0^\pi \sin \theta d\theta = \frac{2ze^2}{4\pi\epsilon_0 v b}$$

and the KE transferred from the particle to the electron is (in nonrelativistic approximation!)

$$T_e = p^2 / 2m_e$$

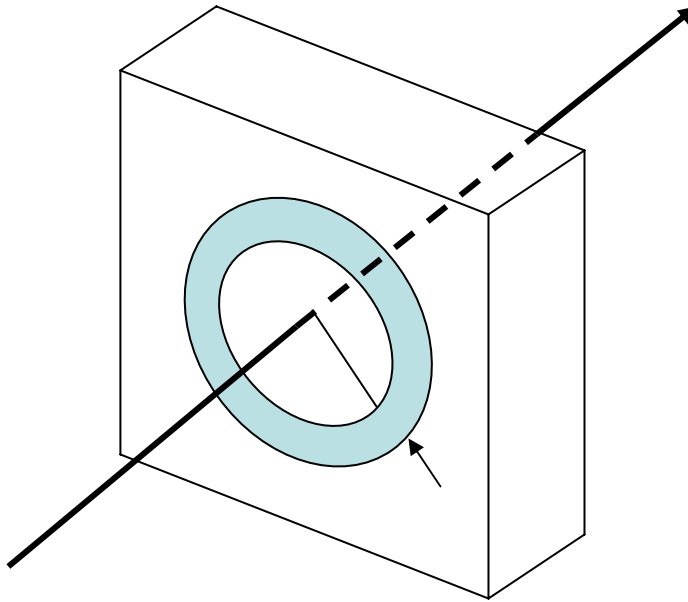

Let the particle pass through a foil of thickness dx , density ρ atomic number Z mass number A then the number of electrons per cm^3 is

$$N_e = N_A Z \rho / A$$

where

$$N_A = 6.022 \times 10^{23} \text{ mol}^{-1}$$

is Avogadro's number

a cylindrical ring, concentric with the flight path of the particle and of radius b and width db has a volume given by

$$dV = 2\pi b db dx$$

and contains $N_e dV$ electrons

therefore the energy loss to all electrons lying between b and $b+db$ is

$$= T_e N_e dV$$

and hence the rate of energy loss of the particle is

$$-\frac{dT}{dx} = 2\pi N_e \int_{b \min}^{b \max} T_e b db$$

and after integration we get

$$\frac{dT}{dx} = \frac{z^2 e^4}{4\pi\epsilon_0^2} N_A \frac{Z\rho}{A} \frac{1}{m_e v^2} \ln \frac{b_{\max}}{b_{\min}}$$

Consider the limits of integration:

naively we would like to put $b_{\max} = \infty$

but that would imply a minimum energy transfer to the electron of $T_{e \min} = 0$, and that means that no ionization can take place;

so we put the minimum energy transfer equal to an average ionization potential I , hence

$$b_{\max}^2 = \frac{z^2 e^4}{8\pi^2 \epsilon_0^2} \frac{1}{m_e v^2} \frac{1}{I}$$

b_{\min} : naively we would put $b_{\min} = 0$

but that corresponds to a head-on collision in which $F_y = 0$ and the impulse in x direction is nonzero.

A simple estimate of b_{\min} is to set

$$T_{e\max} = \frac{1}{2} m_2 v_{e\max}^2 = 2m_e v^2$$

since $v_e = 2v$ in a head-on collision

therefore

$$b_{\min}^2 = \frac{z^2 e^4}{8\pi^2 \epsilon_0^2} \frac{1}{2m_e^2 v^4}$$

and hence

$$b_{\max}^2 / b_{\min}^2 = \frac{2m_e v^2}{I}$$

A more careful analysis that takes account of **QM** and **relativistic effects** yields the following formula:

$$-\frac{dT}{dx} = \frac{z^2 e^4}{4\pi\epsilon_0^2} N_A \frac{Z\rho}{A} \frac{1}{m_e v^2} \left[\ln \frac{2m_e v^2}{I} - \ln(1 - \beta^2) - \beta^2 \right]$$

where $\beta = v/c$

This is called the Bethe-Bloch formula.

Comments:

- (i) For practical calculations it is convenient to replace the elementary charge e by the fine structure constant α :

$$\alpha = \frac{e^2}{4\pi\epsilon_0} \frac{1}{\hbar c}$$

α is a dimensionless number and is equal to $1/137$ in very good approximation (better than 1%):

$$\alpha = 1/137.036$$

\hbar is Planck's constant divided by 2π and
 c is the speed of light

$$\hbar c \simeq 200 \text{ MeV fm}$$

and hence $(\alpha \hbar c)^2 = 2.13 \text{ MeV}^2 \text{ fm}^2$

- (ii) In nuclear physics one likes to measure the thickness of material through which particles pass as ρx (in mg/cm²) (but nuclear physicists still write x for this quantity!)
- (iii) The quantity dT/dx is called the *stopping power* of the material; we can rewrite it in the following form:

$$-\frac{dT}{dx} = 4\pi (\alpha \hbar c)^2 \frac{N_A}{m_e A} \frac{z^2}{v^2} B$$

where

$$B = Z \left[\ln \frac{2m_e c^2 \beta^2}{I} - \ln(1 - \beta^2) - \beta^2 \right]$$

is called the *stopping number*.

(iv) At low speeds $v/c \ll 1$ the stopping power

is roughly inversely proportional to the square of the particle velocity:

$$-\frac{dT}{dx} \propto \frac{1}{v^2}$$

(v) At velocities close to the speed of light the relativistic correction gives rise to an increase of the stopping power

(vi) Between the $1/v^2$ drop and the relativistic rise the stopping power goes through a minimum: this is known as “**minimum ionization**”.

The muon has a very wide, flat minimum, therefore a minimum ionizing particle of large range is a muon candidate.

(vii) Average ionization potential:

This depends on the material; it is a function of the atomic number Z .

On theoretical grounds Bloch has shown that it is to a reasonable approximation proportional to Z :

$$I = kZ \quad \text{where} \quad k \approx 11.5 \text{ eV}$$

Experimental values are shown in the table below:

Z	${}_4\text{Be}$	${}_6\text{C}$	${}_{13}\text{Al}$	${}_{29}\text{Cu}$	${}_{82}\text{Pb}$
I (eV)	64	78	166	323	826
k (eV)	16	13	12.8	11.3	10

4 27. Passage of particles through matter

(from PDT 2004)

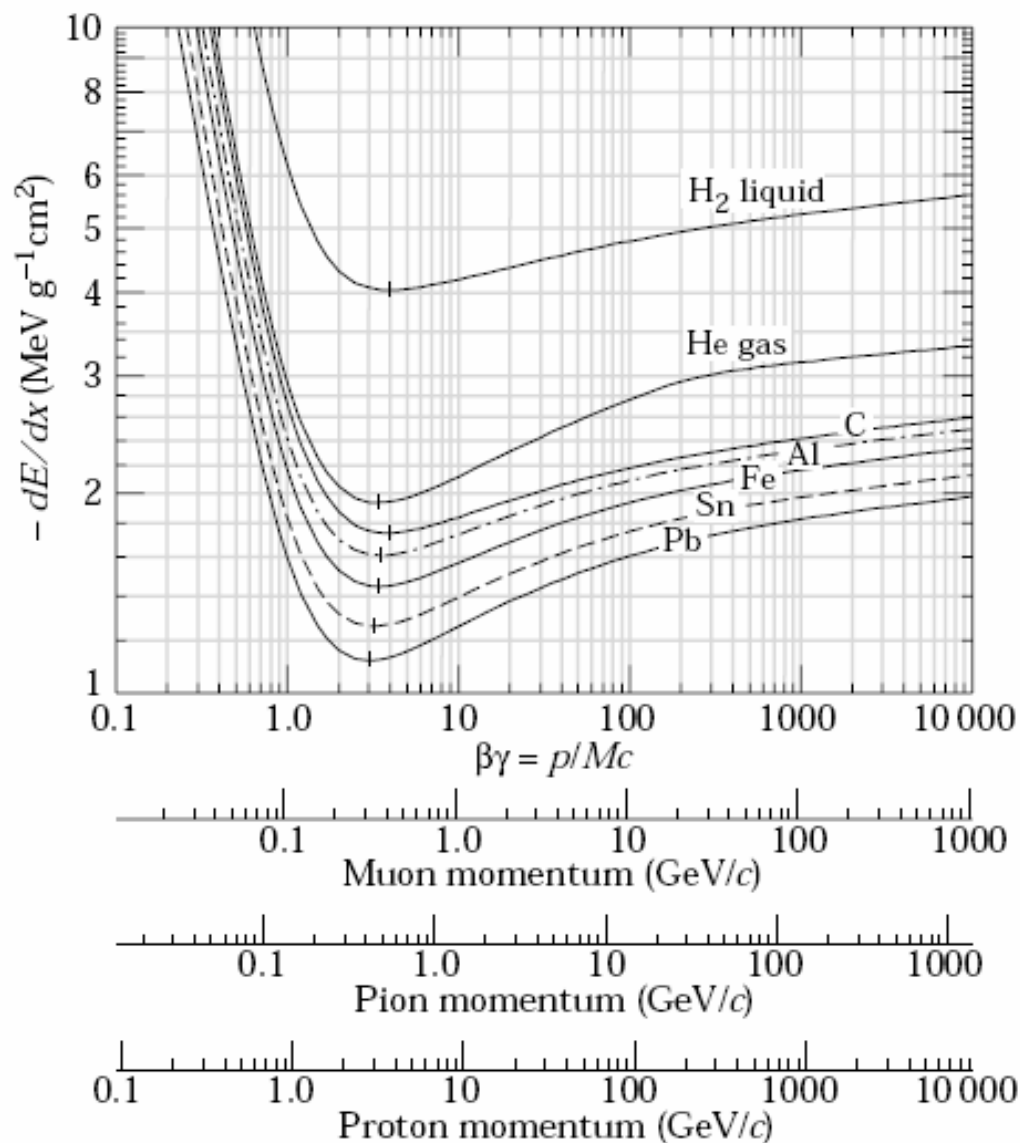

Figure 27.3: Mean energy loss rate in liquid (bubble chamber) hydrogen, gaseous helium, carbon, aluminum, iron, tin, and lead. Radiative effects, relevant for muons and pions, are not included. These become significant for muons in iron for $\beta\gamma \gtrsim 1000$, and at lower momenta for muons in higher- Z absorbers. See Fig. 27.20.

Range

The range R is defined as the distance travelled before the particle stops:

$$R = \int_0^R dx = \int_{T_0}^0 \frac{1}{dE/dx} dE = \frac{4\pi\epsilon_0}{z^2 e^4} \frac{Am_e}{\rho N_A} \int_0^{T_0} \frac{v^2}{B} dE$$

For rough estimates put $B \sim \text{const } Z$

and for nonrelativistic particles

$$E = \frac{1}{2}mv^2 \quad \text{hence} \quad dE = mv dv$$

then

$$R = \text{const} \frac{A}{\rho Z} \frac{m}{z^2} v_0^4$$

Discussion of the Range Formula

- (i) Compare the ranges of two distinct particles of **equal initial velocity** travelling through the same medium:

$$\frac{R_1}{R_2} = \frac{m_1 / z_1^2}{m_2 / z_2^2}$$

for instance proton and α particle:

$$R_p / R_\alpha = m_p / (m_\alpha / 4) \simeq 1$$

- (ii) Compare the ranges of a particle travelling in different media X and Y
approximation: ignore the **Z** dependence in the **log** term, then

$$\frac{R_X}{R_Y} = \frac{A_X / \rho_X Z_X}{A_Y / \rho_Y Z_Y}$$

and if we measure the range in g/cm², then

we have

$$(\rho R)_X / (\rho R)_Y \simeq 1$$

setting

$$A/Z \simeq 2$$

The latter approximation is good enough for rough work; for light elements, up to iron, it is practically exact but not so good for heavy elements:

$$(A/Z)_{Fe} = 56/26 = 2.2$$

$$(A/Z)_{Pb} = 207/82 = 2.5$$

In HE physics experiments one is interested in highly relativistic particles. Therefore the integration of the (inverse) stopping power must be done numerically. The result is displayed in the following figure.

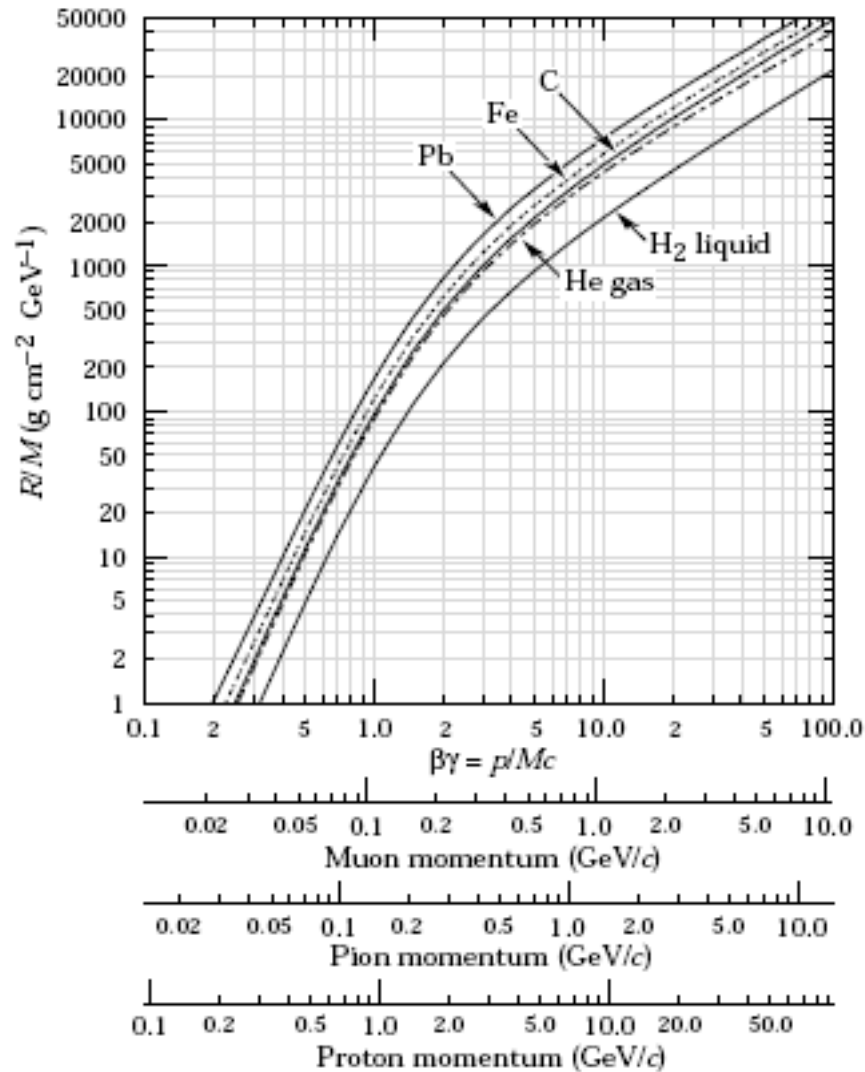

Figure 27.4: Range of heavy charged particles in liquid (bubble chamber) hydrogen, helium gas, carbon, iron, and lead. For example: For a K^+ whose momentum is $700 \text{ MeV}/c$, $\beta\gamma = 1.42$. For lead we read $R/M \approx 396$, and so the range is 195 g cm^{-2} .